

# CS-D507E

Closed Loop Stepper Drive

## *User Manual*



Revision 1.0

©2020 Leadshine Technology Co., Ltd.

## Notice

Read this manual carefully before any assembling and using. Incorrect handling of products in this manual can result in injury and damage to persons and machinery. Strictly adhere to the technical information regarding installation requirements.

This manual is not for use or disclosure outside of Leadshine except under permission. All rights are reserved. No part of this manual shall be reproduced, stored in retrieval form, or transmitted by any means, electronic, mechanical, photocopying, recording, or otherwise without approval from Leadshine. While every precaution has been taken in the preparation of the book, Leadshine assumes no responsibility for errors or omissions. Neither is any liability assumed for damages resulting from the use of the information contained herein.

This document is proprietary information of Leadshine that is furnished for customer use ONLY. Information in this document is subject to change without notice and does not represent a commitment on the part of Leadshine. Therefore, information contained in this manual may be updated from time-to-time due to product improvements, etc., and may not conform in every respect to former issues.

## Record of Revisions

<b>Revision</b>	<b>Date</b>	<b>Description of Release</b>
<i>1.0</i>	<i>September, 2020</i>	<i>Initial Release</i>

## Table of Content

<b>1. Introduction.....</b>	<b>1</b>
1.1 Features.....	1
1.2 Applications.....	1
<b>2. Specifications.....</b>	<b>2</b>
2.1 Electrical Specifications.....	2
2.2 Environment.....	2
2.3 Mechanical Specifications.....	3
2.4 Heat Dissipation.....	3
<b>3. Connections and LED Indication.....</b>	<b>4</b>
3.1 Connector P1 – Control Signals and Digital Outputs Connector.....	4
3.1.1 Pin Assignments of P1.....	4
3.1.2 Connection of Control Signals.....	5
3.1.3 Connection of ALM Signal.....	5
3.1.4 Connection of BRK Signal.....	6
3.2 Connector P2 - Encoder Connection.....	7
3.3 Connector P3 - Motor Connection.....	7
3.4 Connector P4 – Power Supply Connection.....	7
3.5 Connector P5 – Tuning Port.....	7
3.6 LED Light Indication.....	8
<b>4. Motor Selection.....</b>	<b>8</b>
<b>5. Power Supply Selection.....</b>	<b>8</b>
5.1 Regulated or Unregulated Power Supply.....	9
5.2 Power Supply Sharing.....	9
5.3 Selecting Supply Voltage.....	9
<b>6. DIP Switch Configurations.....</b>	<b>9</b>
6.1 S1 - Rotating Switch Configurations.....	9

---

6.2 S2 - DIP Switch Configurations.....	10
6.2.1 Micro Step (SW1-SW4).....	10
6.2.2 Mode Setting (SW5 - SW8).....	11
6.3 S3 - Selector Switch Configurations.....	11
<b>7. Typical Connection.....</b>	<b>11</b>
<b>8. Sequence Chart of Control Signals.....</b>	<b>12</b>
<b>9. Fault Protections.....</b>	<b>12</b>
<b>10. Software Configuration.....</b>	<b>13</b>
<b>11. Accessories.....</b>	<b>13</b>
<b>12. Troubleshooting.....</b>	<b>14</b>
<b>13. Warranty.....</b>	<b>16</b>
<b>Appendix A. Leadshine CS-D507E Compatible Stepper Motors.....</b>	<b>17</b>
<b>Appendix B. Leadshine CS-D507E Compatible Power Supplies.....</b>	<b>18</b>

## 1. Introduction

Leadshine CS-D507E is a closed loop stepper drive designed to solve the loss of step problem in open loop stepper control systems, thus increase system reliability at minimal cost increase. It implements advanced control algorithm of Leadshine based on its tens of years' experience in stepper and servo controls. The CS-D507E is reliable and affordable and performs excellent in many industrial applications such as CNC, medical, electronics, packaging...

The CS-D507E can power 2-phase NEMA 14, 17, 23, and 24 stepper motors with incremental encoders. Compared with traditional open loop stepper systems, a CS-D507E adopted closed loop step system can eliminate potential loss of step, make real-time position error correction, and do not need torque reservation (100% torque implementation). Also it can power the driven stepper motor with reduced heating, lower noise, low vibration...

### 1.1 Features

- No loss of step & No torque reservation & No hunting or overshooting & No tuning for easy setup
- Enhance performance, especially at low speed application (<60RPM)
- Auto-tuning to match wide-range NEMA 17, 23 and 24 closed-loop stepper motors
- Soft-start with no “jump” when powered on
- 20-50VDC supply voltage, max 7.0A output current
- Max 500 KHz input frequency
- 15 micro step settings of 800-51,200 via DIP switches, or 200-51,200 via software (increase by 200)
- 2 out current settings and gain tuning via S1 rotating switch
- Optically isolated inputs with 5V or 24V
- Motor rotating direction setting by SW5
- Closed loop or open loop control setting by SW6
- Step&Direction or CW&CCW pulse type setting by SW7
- Position command filter setting by SW8
- A fault output and a configurable output for alarm or in position
- Over-voltage, over-current protections, position following error, etc

### 1.2 Applications

When a CS-D507E closed loop stepper drive is implemented with a compatible stepper motor with encoder, the closed stepper system can be adopted in many small to median speed applications such as CNC routers, CNC mills, CNC laser cutters, CNC plasma, lab automation instruments, plotters, medical equipment, electronic equipment, small packaging machines, etc.

## 2. Specifications

### 2.1 Electrical Specifications

Parameters	Min	Typical	Max	Unit
Output Current (peak)	0.5	-	7.0	A
Operating Voltage	20	24, 36, 48	50	VDC
Logic signal current	7	10	16	mA
Pulse input frequency (5V @ 50% dutycycle)	0	-	500	kHz
Pulse input frequency (24V @ 50% dutycycle)	0	-	200	KHz
Minimal pulse width	1 $\mu$ S @ 5V, or 2.5 $\mu$ S @ 24V	-	-	$\mu$ S
Minimal direction setup	5.0	-	-	$\mu$ S
Isolation resistance	100			M $\Omega$

### 2.2 Environment

Cooling	Natural Cooling or Forced Cooling	
Operating Environment	Environment	Avoid dust, oil fog and corrosive gases
	Humidity	40%RH – 90%RH
	Operating Temperature	0°C – 40°C (32°F - 104°F)
	Vibration	10-50Hz / 0.15mm
Storage Temperature	-20°C – 65°C (-4°F - 149°F)	
Weight	Approx. 280 g (9.9 Oz)	

## 2.3 Mechanical Specifications

(unit: mm [1inch=25.4mm])

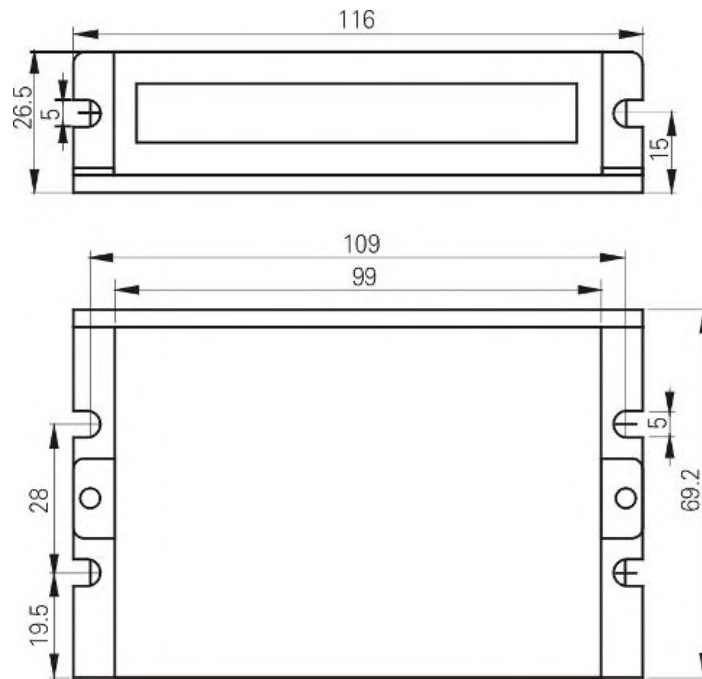

Figure 1: Mechanical specifications

## 2.4 Heat Dissipation

- Temperature of the drive during working should be no more than 65°C (149°F)
- It is recommended to mount the drive vertically to maximize heat dissipation. Mount a cooling fan nearby if necessary.
- If multiple CS-D507E drives are installed, it is suggested to keep a minimal 30mm (1.2 inches) between two of them.

### 3. Connections and LED Indication

A CS-D507E closed loop stepper drive has 5 connection blocks from P1 to P5 (see figure 2).

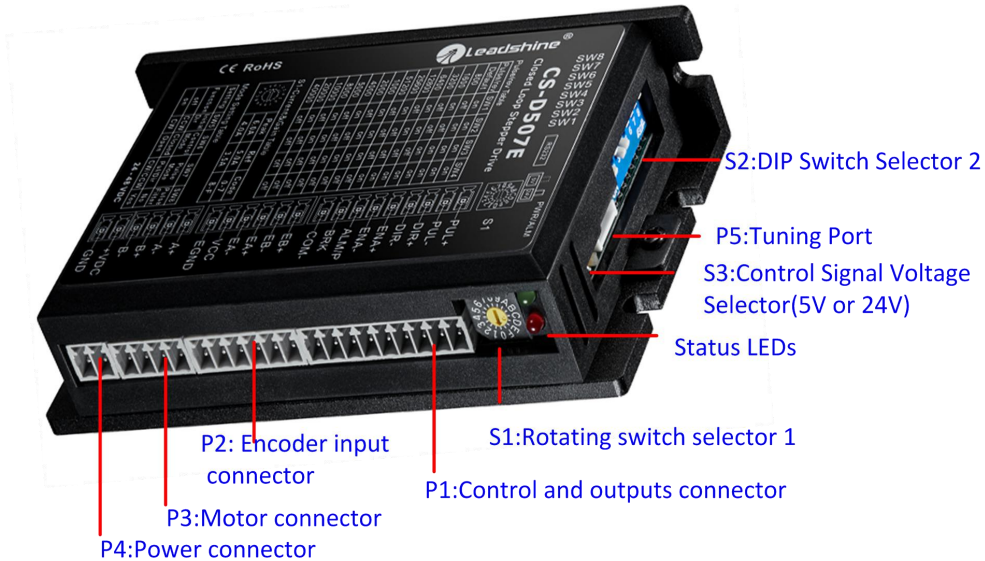

Figure 2: CS-D507E connectors

#### 3.1 Connector P1 – Control Signals and Digital Outputs Connector

##### 3.1.1 Pin Assignments of P1

The P1 connector in Figure 2 contains connections for control signals and 2 digital output.

See the following table for details.

PIN	I/O	Details
PUL+ (CW+)	I	<u>Pulse and Direction Connection:</u> (1) Optically isolated, high level 4.5-5V or 24V, low voltage 0-0.5V
PUL- (CW-)	I	(2) Max 500 KHz input frequency for 5V control signal, while max 200KHz for 24V.
DIR+ (CCW+)	I	(3) The width of PUL signal is at least 1.0 $\mu$ s or 2.5 $\mu$ s, duty cycle is recommended 50%
DIR- (CCW-)	I	(4) Single pulse (step & direction) or double pulse (CW/CCW) is set by DIP Switch SW7
		(5) DIR signal requires advance PUL signal minimum 5 $\mu$ s in single pulse mode
		(6) The factory setting of control signal voltage is 24V, <b>must need</b> to set S3 (figure 2) if it is 5V
ENA+	I	<u>Enable Signals:</u> Optional, <b>no connected default.</b>
ENA-	I	(1) Effective high level is 4.5-24V; Effective low level is 0-0.5V connection
		(2) ENA signal requires advance DIR signal minimum 200ms in single pulse mode,
ALM	O	<u>Alarm:</u> A configurable OC output signal. Can be set to fault output or in position output via software. It takes a sinking or sourcing 100mA current at 5-24V@30mA
BRK	O	<u>Brake:</u> Max. 24@100mA, connect with brake coil, relay and diode.
COMO	O	Common connection of single-end output signals (common-cathode)



**Notes:** (1) Shielding control signal wires is suggested; (2) To avoid/reduce interference, do not tie control signal cables and power wires together; (3) Brake output need to connect a relay and diode

### 3.1.2 Connection of Control Signals

The CS-D507E can accept differential and single-ended control signal inputs (open-collector and PNP output). A CS-D507E has 3 optically isolated control inputs, PUL, DIR, and ENA. Refer to the following two figures for connections of open-collector and PNP signals.

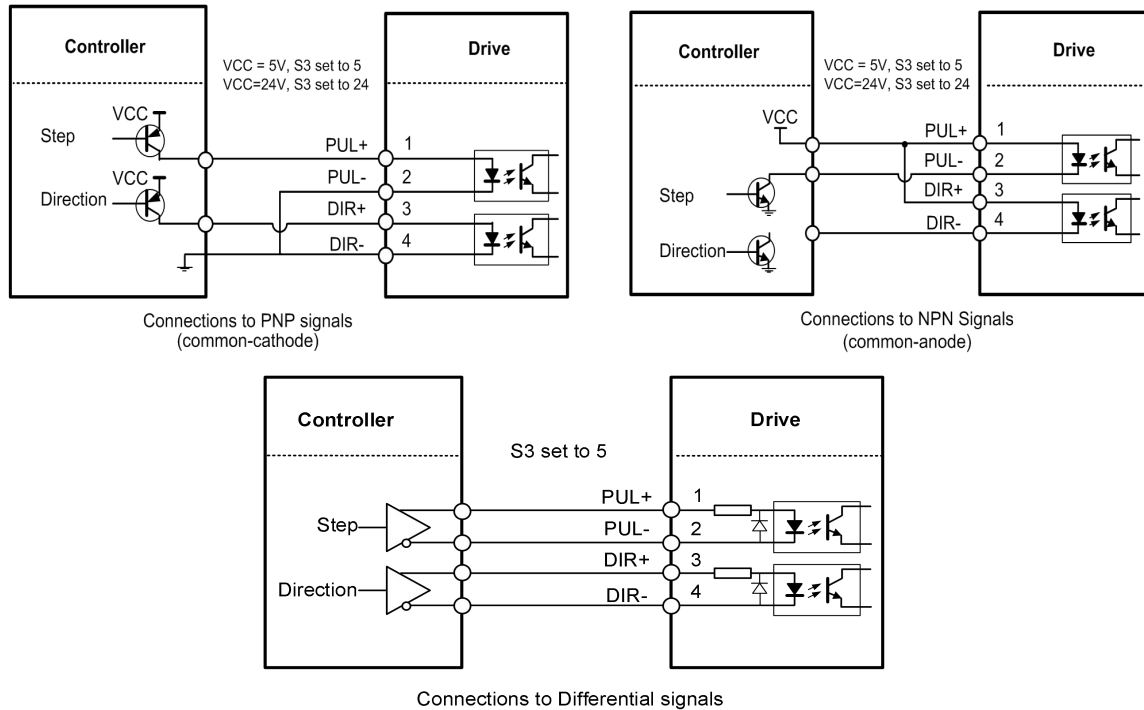

Figure 3: Control Signals Connection

**Notes:** (1) ENA signal is no connected as default;

(2) Control signal amplitude is 24 V as default. If it is 12 V, please set the S3 (Figure 2) selector switch to 5 V first, then connect 1K $\Omega$  resistor; If it is 5V, please set the S3 to 5V.

### 3.1.3 Connection of ALM Signal

- Fault

FAULT output is the default configuration. This output signals a fault condition including over-voltage, over-current, or position following error. This output can be used to drive devices such as a relay, a LED, etc., or as an input signal to electronic devices like a PLC.

For example, in a multi-axis system like a CNC machine when one of the axes fails such a fault output signal can be feedback to the motion controller for a followed action (e.g., auto machine shutdown, auto error clearing, etc.).

- In Position

Use LeadshineMotionStudio software to configure this output as an IN POSITION output. In this case, an output signal can be sent out when the targeted position is in the “Target” range (see *parameter Distance to Send "In position" Output Signal* in software manual) to external devices such as relays, motion controllers, PLCs, IO boards, etc.

Refer to the following figure for ALM connection.

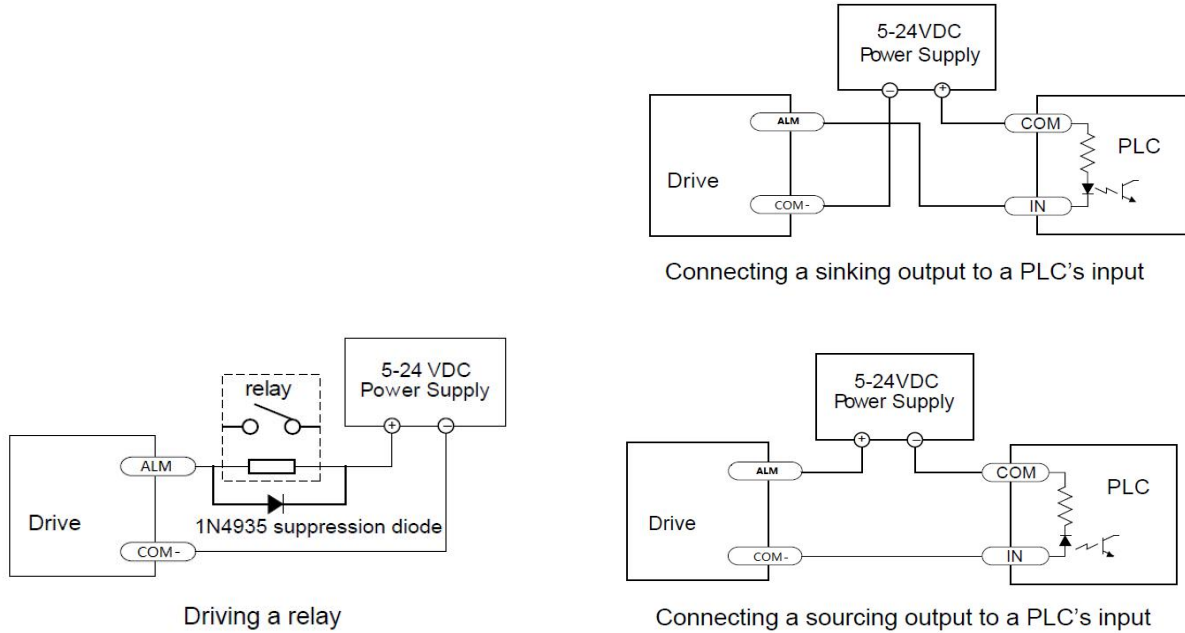

Figure 4: ALM Signals Connection

### 3.1.4 Connection of Brake Signal

This signal can be used for automatic brake control while system power failure.

When use a 24V electromagnetic relay, it is recommended to connect a diode (such as IN4007) in parallel, the polarity should not be reversed. The specific connection is as follows figure.

When use a solid-state relay (SSR), its advantages are fast response, no need to add diodes, no noise; specification such as “Non-contact, DC control DC, current limit protection 0.6-10A”.

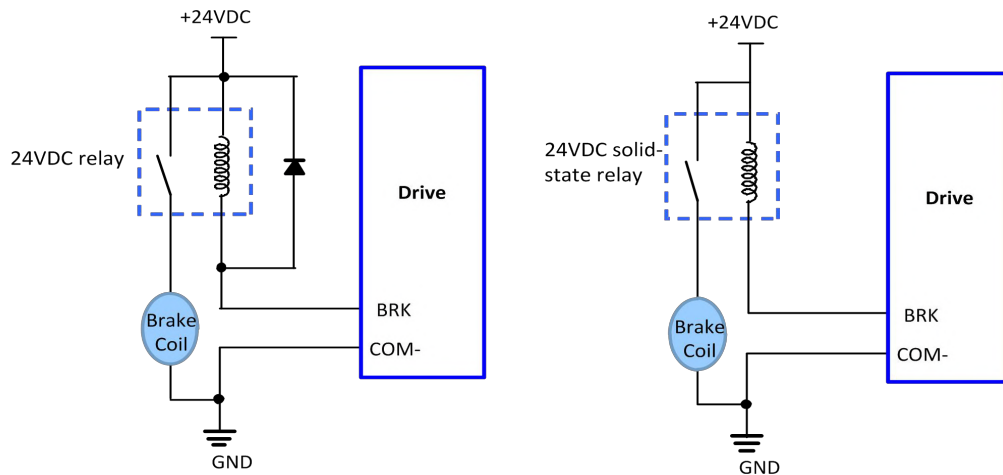

Figure 5: Brake Output Connection

### 3.2 Connector P2 - Encoder Connection

The P2 connector in Figure 2 is for encoder signal connection. Refer to the following table for details.

Drive Pin Name	Description
EB+	Encoder B+ input connection
EB-	Encoder B- input connection
EA+	Encoder A+ input connection
EA-	Encoder A- input connection
VCC	Encoder +5V voltage output connection
EGND	Power ground connection

### 3.3 Connector P3 - Motor Connection

The P3 connector in Figure 2 is for motor connection. Refer to the following table for details.

Pin Name	Details
A+	Stepper motor A+ connection. Connect motor A+ wire to this pin
A-	Stepper motor A- connection. Connect motor A- wire to this pin
B+	Stepper motor B+ connection. Connect motor B+ wire to this pin
B-	Stepper motor B- connection. Connect motor B- wire to this pin

### 3.4 Connector P4 – Power Supply Connection

The P4 connector in Figure 2 is for power supply connection. Refer to the following table for details.

Pin Name	Details
+Vdc	Power supply positive connection. 20-50VDC power supply voltage
GND	Power supply ground connection.

**Notes:** see [Appendix B for compatible Leadshine power supplies](#)

### 3.5 Connector P5 – Tuning Port

The P5 connector in Figure 2 is a RS232 communication port for PC connection. Refer to the following pin definitions.

CS-D507E has a tuning port with RS232 to modify the drive parameters, it is just used to modify parameter, not for equipment control because neither precision nor stability is sufficient. If you need a field bus drive, use a Leadshine RS485 or EtherCAT type drives

The interface definition is as follows:

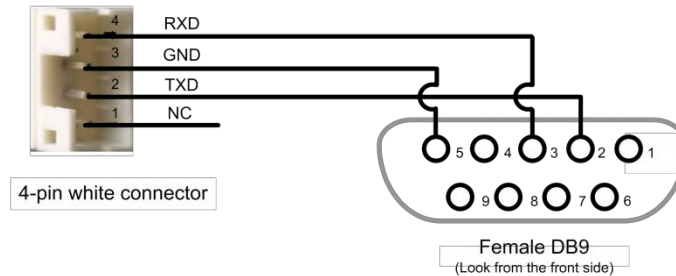

### 3.6 LED Light Indication

There are two LED lights for CS-D507E, one red and one green. The GREEN one is the power indicator which will be always on generally. The RED one is a protection indicator. It is off always when a CS-D507E operates normally, but will flash 1, 2 or 7 times in a 5-second period when error protection is enabled. Different number of flashes indicates different protection type (read Section 9).

## 4. Motor Selection

The CS-D507E is designed to power 2-phase (or 4-phase 0.9 degree) NEMA 17/23/24 stepper motors under 10000-line incremental encoders (recommend 1000-line). Leadshine offers many high-performance stepper motors compatible with the CS-D507E which you can find in the Appendix A of this document. The CS-D507E can also power similar stepper motors with incremental encoders from third-party suppliers.

**Notes:** Contact Leadshine for stepper motor with 2000-line, 2500-line, 5000-line encoders.

## 5. Power Supply Selection

The CS-D507E can power small and medium size closed loop stepper motors (frame size from NEMA17 to 24) from Leadshine (see Appendix A) or other motor manufacturers. To get good system performance, it is important to select proper supply voltage and output current. Generally speaking, supply voltage determines the high speed performance of the motor, while output current determines the output torque of the driven motor (particularly at lower speed). Higher supply voltage will allow higher motor speed to be achieved, at the price of more noise and heating. If the motion speed requirement is low, it's better to use lower supply voltage to decrease noise, heating and improve reliability.

**Notes:** See Appendix B at the end of this document for Leadshine CS-D507E compatible switching power supplies specially designed for stepper & servo controls.

## 5.1 Regulated or Unregulated Power Supply

Both regulated and unregulated power supplies can be used to supply the drive. However, unregulated power supplies are preferred due to their ability to withstand current surge and fast response for current change. If you prefer to a regulated power supply, it is suggested to choose such a power supply specially designed for stepper/servo controls such as Leadshine RPS series (<http://www.leadshine.com/producttypes.aspx?producttype=regulated-switching>). Or, in the case when only normal switching power supplies are available, it is important to use “OVERSIZE” high current output rating power supplies (for example, using a 4A power supply for 3A stepper motor) to avoid problems such as current clamp. On the other hand, if unregulated supply is used, one may use a power supply of lower current rating than that of motor (typically 50%-70% of motor current). The reason is that the drive draws current from the power supply capacitor of the unregulated supply only during the ON duration of the PWM cycle, but not during the OFF duration. Therefore, the average current withdrawn from power supply is considerably less than motor current. For example, two 3A motors can be well supplied by one power supply of 4A rating.

## 5.2 Power Supply Sharing

Multiple CS-D507E drives can share one power supply to save space and reduce cost, if that power supply has enough power capacity. To avoid cross interference, connect each stepper drive directly to the shared power supply separately. To avoid cross interference, DO NOT daisy-chain connect the power supply input pins of the Drivers. Instead connect them to power supply separately.

## 5.3 Selecting Supply Voltage

The CS-D507E is designed to operate within 20-50VDC voltage input. When selecting a power supply, besides voltage from the power supply power line voltage fluctuation and back EMF voltage generated during motor deceleration needs also to be taken into account. Ideally it is suggested to use a power supply with the output of 20-48VDC, leaving room for power line voltage fluctuation and back-EMF.

Higher supply voltage can increase motor torque at higher speeds, thus helpful for avoiding losing steps. However, higher voltage may cause bigger motor vibration at lower speed, and it may also cause over-voltage protection or even drive damage. Therefore, it is suggested to choose only sufficiently high supply voltage for intended applications.

# 6. DIP Switch Configurations

## 6.1 S1 - Rotating Switch Configurations

This rotating switch is used to set the peak current of the drive and motion gain, from the motor phase current and application requirements.

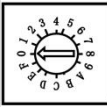
	Peak Current	Code	Velocity loop Ki	Position loop Kp	Velocity loop Kp	Remark
	<b>6.0A</b>	0 (factory and default)	0	25	25	1) Velocity loop Ki indicates the stop time and position accuracy, “0” indicates the stop time is short, but the position error is slightly larger. “16” means the stop time is long, but the position error is smaller. As usual “0” meets most applications.
	(Actual output current)	1	0	50	15	
		2	0	75	10	

	fluctuates from 3-6A following the load)	3	0	100	5	2) Position loop Kp and velocity loop Kp is a pair of composite parameters that represent stiffness. “25” and “25” composite parameters indicate the stiffness is weak, “100” and “5” composite parameters indicate the rigidity is strong. Sometimes if the motor will rotate after stopping, it can increase the value of position loop Kp, but if the value is too large, the motor will have noise.  3) Usually keep factory settings
		4	16	25	25	
		5	16	50	15	
		6	16	75	10	
		7	16	100	5	
	<b>4.0A</b>  (Actual output current fluctuates from 2-4A following the load)	8	0	25	25	
		9	0	50	15	
		A	0	75	10	
		B	0	100	5	
		C	16	25	25	
		D	16	50	15	
		E	16	75	10	
		F	16	100	5	

Note: “factory” means the factory switch setting, “default” means the parameters can be set by Leadshine software.

## 6.2 S2 - DIP Switch Configurations

The 8-bit is located on the side (DIP switch S2 in Figure 2) and used to configure settings of micro step resolution, output current, and motor standstill current as shown below.

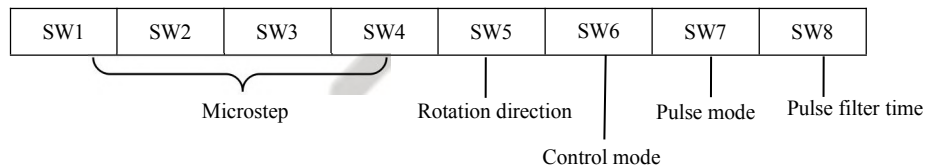

Figure 6: DIP switches

### 6.2.1 Micro Step (SW1-SW4)

Each CS-D507E has 15 microstep settings which can be configured through DIP switches SW1, SW2, SW3 and SW4. See the following table for detail.

Micro step	Pulses/Rev. (for 1.8°motor)	SW1	SW2	SW3	SW4
8 (default)	<b>1600</b>	on	on	on	on
4	<b>800</b>	off	on	on	on
8 (factory)	<b>1600</b>	on	off	on	on
16	<b>3200</b>	off	off	on	on
32	<b>6400</b>	on	on	off	on
64	<b>12800</b>	off	on	off	on
128	<b>25600</b>	on	off	off	on
256	<b>51200</b>	off	off	off	on

5	<b>1000</b>	on	on	on	off
10	<b>2000</b>	off	on	on	off
20	<b>4000</b>	on	off	on	off
25	<b>5000</b>	off	off	on	off
40	<b>8000</b>	on	on	off	off
50	<b>10000</b>	off	on	off	off
100	<b>20000</b>	on	off	off	off
200	<b>40000</b>	off	off	off	off

Note: “factory” means the factory switch setting, “default” means the parameters can be set by Leadshine software.

### 6.2.2 Mode Setting (SW5 - SW8)

	Function	ON	OFF
<b>SW5</b>	Rotation Direction	CW (clockwise)	CCW (counterclockwise)
<b>SW6</b>	Control Mode	Open loop control	Closed loop control
<b>SW7</b>	Pulse Mode	CW/CCW (double pulse)	PUL/DIR (single pulse)
<b>SW8</b>	Pulse Filter Time	Yes (10ms)	No (1.5ms)

Remark: (1) CS-D507E supports open-loop mode, which can be used when the encoder is damaged or judging whether the value of the position loop gain is wrong; (2) “Pulse Filter Time” means S-curve acceleration, to improve motion smoothness and high-speed start frequency in many circumstances. The Filter Time value must be set to the same for each CS-D507E in multi-axis applications

### 6.3 S3 - Selector Switch Configurations

The 1-bit selector is located on the top (S3 in figure 2), used to configure the voltage of control signals. For the safety of optically coupled, the factory setting is 24V, which no need to connect 2K resistors, making it easier to use. When the voltage of the control signal is 5V, the S3 must be set to 5V, otherwise, the motor will not work.

## 7. Typical Connection

A complete closed loop stepper system should include a stepper motor with encoder, CS-D507E drive, power supply and controller (pulse generator). A typical connection is illustrated in figure 7.

	fluctuates from 3-6A following the load)	3	0	100	5	2) Position loop Kp and velocity loop Kp is a pair of composite parameters that represent stiffness. “25” and “25” composite parameters indicate the stiffness is weak, “100” and “5” composite parameters indicate the rigidity is strong. Sometimes if the motor will rotate after stopping, it can increase the value of position loop Kp, but if the value is too large, the motor will have noise.  3) Usually keep factory settings
		4	16	25	25	
		5	16	50	15	
		6	16	75	10	
		7	16	100	5	
	4.0A  (Actual output current fluctuates from 2-4A following the load)	8	0	25	25	
		9	0	50	15	
		A	0	75	10	
		B	0	100	5	
		C	16	25	25	
		D	16	50	15	
		E	16	75	10	
		F	16	100	5	

Note: “factory” means the factory switch setting, “default” means the parameters can be set by Leadshine software.

## 6.2 S2 - DIP Switch Configurations

The 8-bit is located on the side (DIP switch S2 in Figure 2) and used to configure settings of micro step resolution, output current, and motor standstill current as shown below.

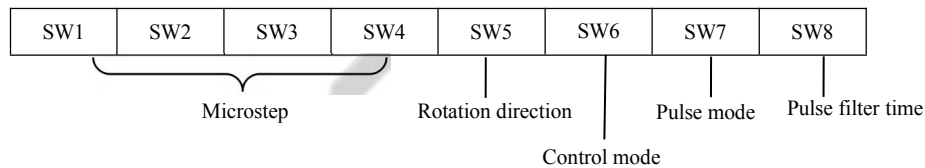

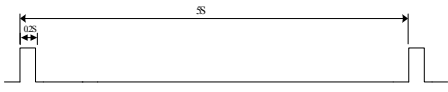
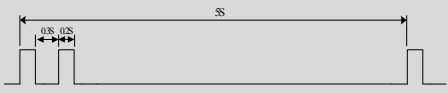



Figure 6: DIP switches

### 6.2.1 Micro Step (SW1-SW4)

Each CS-D507E has 15 microstep settings which can be configured through DIP switches SW1, SW2, SW3 and SW4. See the following table for detail.

Micro step	Pulses/Rev. (for 1.8°motor)	SW1	SW2	SW3	SW4
8 (default)	<b>1600</b>	on	on	on	on
4	<b>800</b>	off	on	on	on
8 (factory)	<b>1600</b>	on	off	on	on
16	<b>3200</b>	off	off	on	on
32	<b>6400</b>	on	on	off	on
64	<b>12800</b>	off	on	off	on
128	<b>25600</b>	on	off	off	on
256	<b>51200</b>	off	off	off	on

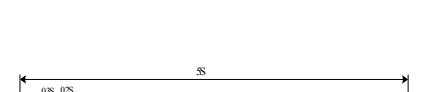

Blink time(s)	Sequence wave of red LED	Description	Trouble shooting
1		Over-current	Turn off the power immediately. a) Check wiring is short-circuited or not; b) Check motor is short-circuited or not.
2		Over-voltage	Turn off the power immediately. a) Check if the power voltage is higher than 90VDC
3		Chip error	Restart the power supply, if the drive is still alarm, please contact after-sale
4		Fail to lock motor shaft	a) The drive is not connected to a motor. b) If alarm is occurred when connect a motor, please check the motor wiring.
5		EEPROM error	Restart the power supply, if the drive is still alarm, please contact after-sale
6		Fail to auto tuning	Disable auto-tuning function by Leadshine MotionStudio software
7		Position following error	a) The value of position following error is set too small. b) Motor torque is not enough, or motor speed is too high. c) Motor wiring error, check wiring
Always	-	PCB board is burned out	Contact after-sale a) Power supply connection is wrong

When above protections are active, the motor shaft will be free or the red LED blinks. Reset the drive by repowering it to make it function properly after removing above problems.

## 10. Software Configuration

The CS-D507E is designed for simple setup and implementation. For most applications, no software configuration or tuning is needed especially when driving Leadshine stepper motors with encoders (see Appendix A). If you want to do fine tuning or custom configurations such as micro-step, current percentage change..., you can use Leadshine's free MotionStudio software to make the changes.

## 11. Accessories

If you plan to use the Leadshine software, contact your supplier or Leadshine to purchase the RS232 cable with part number [CABLE-PC-1](#) for connecting the CS-D507E to a computer with Windows 7/8/10 installed. In the case of using

USB to RS232 conversion, contact your supplier or Leadshine for such a cable with part number [USB2.0-232](#) which has been verified working fine.



[CABLE-PC-1](#)

(RS232 tuning cable)



[USB2.0-232](#)

(USB to RS232 Conversion Cable)

## 12. Troubleshooting

If your drive does not operate properly, the first step is to identify whether the problem is electrical or mechanical in nature. The next step is to isolate the system component that is causing the problem. As part of this process you may have to disconnect the individual components that make up your system and verify that they operate independently. It is important to document each step in the troubleshooting process. You may need this documentation to refer back to at a later date, and these details will greatly assist our Technical Support staff in determining the problem should you need assistance.

Many of the problems that affect motion control systems can be traced to electrical noise, controller software errors, or mistake in wiring.

Symptoms	Possible Problems	Solutions
<b>Motor is not rotating</b>	No power	Connect power supply correctly
	Microstep resolution setting is wrong	Setting appropriate microstep
	Fault condition exists	Check wiring and restart power
	The drive is disabled	Drive restore factory setting, and keep ENA+, ENA- input signals unconnected.
<b>Wrong motor rotation direction</b>	The Direction signal level is reverse	Toggling the SW5 DIP switch
<b>The drive in fault</b>	Red light flashes once in a 5-second period	The motor coil may short circuit or exiting the wrong wiring
	Red light flashes twice in a 5-second period	The power supply exceeds Max. operation voltage
	Red light flashes 4-times in a 5-second period	Motor wiring poor contact, or motor wiring wrong
	Red light flashes 7-times in a 5-second period	If using Leadshine's motor, maybe motor wiring poor contact; If using 3 <sup>rd</sup> motor,

		need to swap the wiring of motor phase A+ and phase A-
<b>Motor lost steps</b>	Control signal is too weak	Ensure the current of control signal is within 7-16mA
	Control signal is interfered	Don't tie the control signal cable with power cable together
	Control Signal timing wrong	ENA signal should ahead pulse signal 500ms
	Something wrong with motor coil	Check the motor is normal
<b>Motor stalls during acceleration</b>	Current setting is too small	Choose another power supply with lager power or increase the output current of drive
	Motor is undersized for the application	Choose another motor with higher torque
	Acceleration is set too high	Reduce the acceleration
	Power supply voltage too low	Choose another power supply with large voltage output
<b>Excessive motor &amp; drive heating</b>	Inadequate heat sinking / cooling	Refer to chapter 2.4
	Motor peak current setting is too high	Reduce the current value refer to motor datasheet
<b>Motor vibration when power on</b>	Position loop Kp is too high	Reduce the position loop Kp value
<b>Motor only one direction</b>	DIR inputs is burned	Check whether S1 is set to 5V, while the actual control signal is 24V
	Mismatched pulse types	Check if SW7 is set incorrectly

## 13. Warranty

### Twelve Month Warranty

Leadshine Technology Co., Ltd. warrants its products against defects in materials and workmanship for a period of 12 months from shipment out of factory. During the warranty period, Leadshine will either, at its option, repair or replace products which proved to be defective.

### Exclusions

The above warranty does not extend to any product damaged by reasons of improper or inadequate handlings by customer, improper or inadequate customer wirings, unauthorized modification or misuse, or operation beyond the electrical specifications of the product and/or operation beyond environmental specifications for the product.

### Obtaining Warranty Service

To obtain warranty service, please contact your seller to obtain a returned material authorization number (RMA) before returning product for service.

### Shipping Failed Products

If your product fail during the warranty period, please contact your seller for how and where to ship the failed product for warranty or repair services first, you can also e-mail customer service at [tech@leadshine.com](mailto:tech@leadshine.com) to obtain a returned material authorization number (RMA) before returning product for service. Please include a written description of the problem along with contact name and address.

## Appendix A. Leadshine CS-D507E Compatible Stepper Motors

The following Leadshine stepper motors with 1000-line encoders have been tested working with the CS-D507E closed loop stepper drive.

Model	Frame Size (NEMA)	Torque (N.m / Oz-In)	Series	Length (mm / inch)	Notes
CS-M21702	17	0.2 / 28	CS-M	56/2.20	-
CS-M21704		0.4 / 57		63/2.48	-
CS-M21706		0.6 / 85		70/2.76	-
CS-M21708		0.8 / 113		83/3.27	-
CS-M22306	23	0.6 / 85		60/2.36	-
CS-M22313		1.3 / 184		73/2.87	-
CS-M22323		2.3 / 326		95/3.74	-
CS-M22323-S		2.3 / 326		95/3.74	0.25-inch (6.35-mm) shaft
CS-M22326		2.6 / 368		103/4.06	-
CS-M22326-S		2.6 / 368		105/4.06	0.25-inch (6.35-mm) shaft
CS-M22321-L		2.1 / 368		86/3.39	-
CS-M22331-L		3.1 / 439		105/4.13	-
CS-M22331-L-S		3.1 / 439		105/4.13	-
CS-M22313B		1.3 / 184		117/4.61	24VDC brake integrated
CS-M22323B		2.3 / 326		137/5.39	24VDC brake integrated
CS-M22313WP		1.2 / 184		95/3.74	IP65 rated
CS-M22323WP	2.0 / 283	114/4.49	IP65 rated		

Note: all above stepper motors are mounted with 1000-line incremental encoders, also can contact Leadshine for stepper motors with 2500-line, 5000-line encoders.

## Appendix B. Leadshine CS-D507E Compatible Power Supplies

It is highly suggested to use the following Leadshine power supplies to power CS-D507E to get optimized performance. Those power supplies are specially designed for stepper and servo controls.

Model	Output Voltage (VDC)	Continuous Current(A)	Peak Current(A)	Input Voltage	Power (W)	Dimensions (mm)	Weight (Kg)
LSP-260-24	24	10.8	19.4	220VAC $\pm$ 10% or 110 VAC $\pm$ 10%	260	199*110*50	0.8
LSP-360-24	24	15	27		360	199*110*50	0.8
LSP-360-36	36	10	18		360	215*115*30	0.7
LSP-360-48	48	7.5	13.5		360	215*115*30	0.7
LSP-400-60	60	6.7	12		400	215*115*30	0.7